

# WindPro® Storm Banner Bracket Assembly Instructions

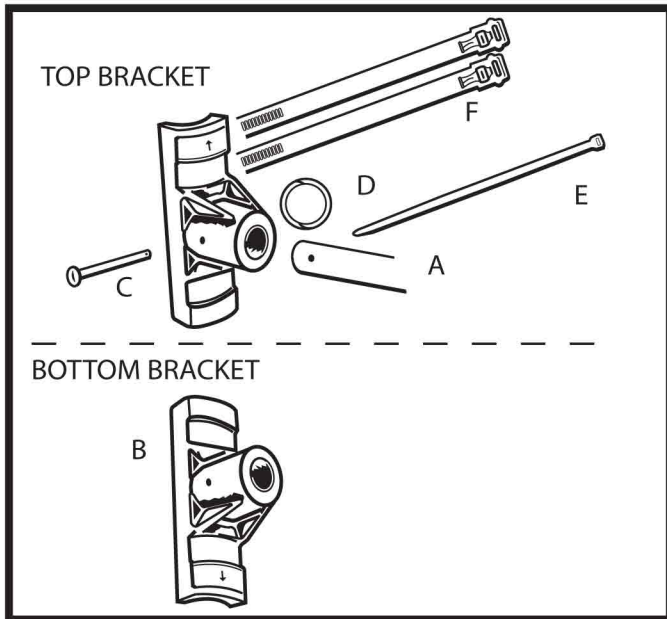

## ASSEMBLY INSTRUCTIONS

- 1) Place fiberglass reinforced rod (a) firmly into the aluminum bracket base (b). Twist until holes line up.
- 2) Insert clevis pin (c) through holes.  
NOTE: The hole in rod & bracket must line up exactly and may be tight. Tap clevis pin with mallet/hammer through hole if needed.
- 3) Thread Split ring (d) through hole in clevis pin to keep all pieces together.
- 4) Place top bracket/rod assembly at desired height on pole - Arrow on aluminum bracket must be facing (up) away from the banner. Using 2 clamps (f) secure top bracket to pole.  
NOTE: You must use screwdriver to achieve correct tensioning.
- 5) Measure down the pole to desired banner length and place bottom bracket/rod assembly to pole. Secure bracket assembly to pole using 2 clamps (f), same as in step 4. NOTE: Arrow on aluminum bracket must be facing away from the banner or banner will not fit properly. TIP!! After installing top bracket you can slide banner onto top bracket and let fall to determine where the bottom bracket will be placed on the light pole.
- 6) Slide the banner pockets over the top/bottom bracket arms and fasten banner to bracket system using furnished cable ties (e).  
NOTE: Cable ties is attached through the grommet on banner and kick-out ring on bracket - secure tightly, but not to cause wrinkle in banner.

### "SINGLE BRACKET SET" INVENTORY LIST

- 2 (a) Fiberglass Rod  
(can be customized to any length)
- 2 (b) Aluminum Bracket Bases
- 2 (c) Clevis Pins
- 2 (d) Split-Rings
- 2 (e) Cable Ties
- 4 (f) SS Band Clamp (40")

### "DOUBLE BRACKET SET" INVENTORY LIST

- 4 (a) Fiberglass Rod  
(can be customized to any length)
- 4 (b) Aluminum Bracket Bases
- 4 (c) Clevis Pins
- 4 (d) Split-Rings
- 4 (e) Cable Ties
- 4 (f) SS Band Clamp (40")

## RECOMMENDED INSTALLATION TOOLS

- Slotted Screw Driver\*
- Hammer or Mallet
- Extension Ladder or Boom Truck

### •Installation Note:

All clamps should be tightened with only a screwdriver. Powered tools will break the clamps

## DOUBLE BRACKET SYSTEM INSTALLATION

If you are installing double brackets follow all of the steps above except use (2) Bracket/Rod assemblies top and bottom - Parallel to each other.

### NOTE:

You will still use the same amount of clamps (f) to secure double system to pole. For double bracket systems you may find it easier to install brackets first and them assemble fiberglass rods into brackets.

WindPro™ Banner Brackets are warranted against manufacturer defect only. Over time the aluminum base will oxidize, this will NOT effect performance of the bracket system. If you are installing on an aluminum pole it will eventually match the sheen. ALWAYS inspect the stainless steel band clamps when reinstalling bracket system. It is more cost effective to replace at time of reinstallation than when failure occurs.

Manufactured by:  
Niedo Group, Inc.  
9665 SW Allen Blvd. Suite 113  
Beaverton, OR 97005  
Tel: 503-245-3335 ♦ www.DisplayStar.com